



# 6378-C/6378A-C

## SOFT SERVE FREEZER

Two Flavor, Floor, Digital Control  
A: Pump Feed Model

Most **Powerful** and **Versatile**  
Two flavor high capacity floor model  
for ice cream, frozen yogurt and  
much more

### Fast Freeze Down

Patented high efficiency heat exchanger allows fast freeze down with low energy consumption

### Digital Control and Display

Microprocessor control provides access to system settings and additional functions. Digital interface displays critical info as system status, temperatures, dispense count, errors, etc.

### Auto Programming

Allows automatic switching of operation modes based on preset schedules

### Standby

Maintains product temperature in both mix hopper and freezing cylinder below 4.4°C (40°F) overnight

### Hopper Agitator

Maintain product consistency and prevent product separation

Ideal for high capacity outlets to serve ice cream, frozen yogurt, gelato or sorbet. Fully loaded with all standard options. Small footprint helps save floor space.



### Soft System Start

Slow motor start reduces equipment noise and stress on drive train

### Direct Drive Transmission

Eliminates consumable moving parts and increases transmission efficiency

### Safety Protections

- Low temperature and motor overload shutoffs to protect in the event of cylinder freeze up
- High pressure switch to prevent compressor overheating

### Defrost for Cleaning

Increases efficiency during cleaning by heating frozen product in cylinder

### Quick Freeze

Turn on freeze immediately to freeze down to serving viscosity when quick service is required after long idle period

### Self-closing Valve with Speed Control

Automatically prevents product overflow after dispense; Provides flexibility in dispense rate control



# 6378-C / 6378A-C

# SOFT SERVE FREEZER

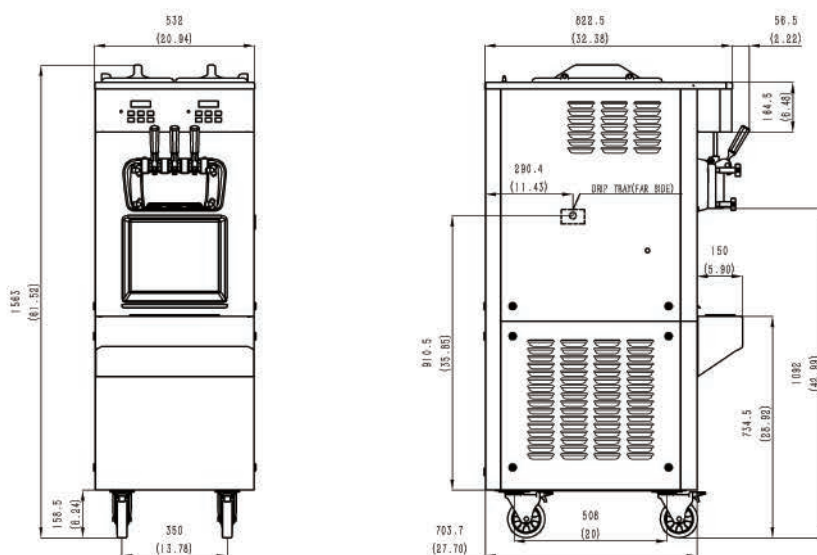

## SPECIFICATIONS

Flavors	2 + Twist
Freezing Cylinders	2 x 3.2L / 3.4qt
Mix Hoppers	2 x 15L (10L for A)
Output Capacity (80 grams)	720 serves/hr
Clearance Requirements	152mm/6" on back

## Weight

	Kg/lb (Gravity)	Kg/lb (Pump)
Net	253 / 562	263 / 585
Shipping	273 / 607	283 / 629
Volume	1.09 CBM / 38.62 CBF	

## Dimensions

	Net (mm/in)	Shipping (mm/in)
Width	532 / 20.9	710 / 28.0
Depth	704 / 27.7	890 / 35.0
Height	1563 / 61.5	1730 / 68.1

## Electrical

	MFS	MCA	Power(kW)
220-240/50/3	15	11	4.4
208-230/60/3	30	23	4.8
208-230/60/1	30	24	4.9

## FEATURES

Control Systems	Two, Digital
Refrigerated Hoppers	✓
Hopper Agitators	✓
Temperature Displays	✓
Standby Mode	✓
Auto Closing Dispensing Valves	✓
Dispensing Speed Control	✓
Low Mix Indicator Light & Alarm	✓
Low Temperature Protection	✓
Motor Overload Protection	✓
High Pressure Protection	✓
Defrost & Quick Freeze	✓
Soft Start	✓
Direct Drive Pump (A only)	✓

## AVAILABLE OPTIONS

Water Cooled	✓
Top Air Discharge Chute	✓

• Above specifications are subject to change without notice